

## Installation and Operating Instructions QuietAir 150mm Axial Fan



MODEL:QT 150HT - Two Speed Fan (220/260m<sup>3</sup>/hr)  
With Delay Start, Automatic Humidity  
control and Timer



- Low Energy
- Quiet
- Long Life
- Extra Safe
- Delay Start

# Installation and Operating Instructions

## **CONTENTS**

### **Chapter 1. GENERAL INSTALLATION AND OPERATION INSTRUCTIONS**

- 1.0 Important Information
- 1.1 Warnings
- 1.2 Safety Instructions
- 1.3 Warranty claims – Disclaimer
- 1.4 Regulations - Guidelines
- 1.5 Transport
- 1.6 Acceptance of delivery
- 1.7 Storage
- 1.8 Operational area
- 1.9 Performance data
- 1.10 Noise data

### **Chapter 2. GENERAL NOTES**

- 2.0 Qualification of staff
- 2.1 Touch protection
- 2.2 Motor protection
- 2.3 Start-up performance

### **Chapter 3. SPECIFICATIONS / DIMENSIONS**

- 3.0 Specifications
- 3.1 Product lifetime
- 3.2 Accessories
- 3.3 Dimensions

### **Chapter 4. FUNCTION**

- 4.0 Function description

### **Chapter 5. CLEANING / DEINSTALLATION**

- 5.0 Cleaning
- 5.1 Cover dismantling

### **Chapter 6. INSTALLATION**

- 6.0 Scope of delivery / Mechanical installation
- 6.1 Preparation for wall mounting
- 6.2 Installation
- 6.3 Electrical installation
- 6.4 Cable connection
- 6.5 Mounting
- 6.6 Operation

### **Chapter 7. INSTALLER FUNCTION**

- 7.0 Function description QT150 HT

### **Chapter 8. CARE AND MAINTENANCE**

- 8.0 Care and maintenance
- 8.1 Troubleshooting
- 8.2 Decommissioning and disposal

1.0 Important information

To ensure the proper functioning and for your own safety, the manual should be read and observed.

This document is part of the product and should be available at all times to ensure the safe operation of the fan. All equipment-related safety regulations should be adhered to.

DANGER

1.1 Warnings

**The adjacent symbols are safety warnings. To avoid any risk of injury and dangerous situations, all safety regulations (symbols) in this document should be strictly observed.**

WARNING

CAUTION

DANGER

1.2 Safety Instructions

For use, connection and operation please refer to these instructions. If in doubt, contact the manufacturer for advice. Other information is relevant to standards and legislative texts.

**⚠ For all work involving operation of the fan, general applicable safety and accident prevention regulations should be observed.**

- **All electrical work and commissioning should be carried out by authorized and qualified electricians.**
- **Maintenance and installation work should be carried out by competent personnel.**
- **Before cleaning, maintenance and installation work or before opening the terminal compartment the following points must be observed:**
  - **Disconnect the fan from power supply (all-poles) and secure against restarting!**
  - **Wait until all rotating parts have stopped moving!**
  - **After rotating parts have stopped moving, waiting period of 3 min should be observed; dangerous voltages can occur by internal capacitors even after disconnection from the network!**
- **All equipment-related safety regulations should be observed! If necessary, further country-specific regulations should be complied with!**
- **Contact protection (or Protection against accidental contact) should be insured according to DIN EN 13857 (see Chapter 2.1)!  
Contact with rotating parts should be avoided.**

- **Ensure a uniform inflow and free outlet!**
- **During operation within a fire place in the ventilated room, sufficient air supply should be provided in all operating conditions (please contact chimney sweep).  
Valid local regulations and laws should be observed!**
- **The QT150 HT fan should not to be used by children and persons with reduced physical, mental or sensory capacities, without proper practical experience or expertise, unless they are controlled or instructed on the product operation by the person(s) responsible for their safety. Children should not play with the device. Cleaning and maintenance must not be carried out by children without supervision.**

### **1.3 Warranty claims – Disclaimer**

All versions of this manual should be observed; otherwise the guarantee will be annulled. The same applies to liability claims against Airflow Developments Limited. Any potential damages are not a subject of the guarantee. Changes and modifications to the product are not allowed and will result in a loss of conformity - in such case any warranty and liability will be excluded.

### **1.4 Regulations – Guidelines**

The fan should be properly installed and used for its intended purpose. The product complies with the valid regulations and CE-guidelines at the time of its production.

### **1.5 Transport**

The fan is factory-packed so that it is protected against normal transport loads. It is recommended to leave the fan in the manufacturer's original package.

### **1.6 Acceptance of delivery**

A visual inspection upon delivery should be performed including damage and type accuracy check. In the event of there being any damage, the necessary notification of claim immediately has to be reported to the carrier. Any delay in complaint will result in a loss of benefit entitlement.

### **1.7 Storage**

When storing for a long period of time, avoid harmful impacts by following these steps: protect the motor by dry, air and dustproof package (plastic bags with drying agent and moisture indicator). The product should be stored in a vibration-free and water-protected premise at a constant temperature ranging from -20 °C up to + 40 °C. In compliance to Chapter 8, when storing a product for more than three months (motor standstill), maintenance should be determined before commissioning. In case of transshipment (especially over longer distances: e.g. sea), the packaging has to be checked whether it is suitable for transport and on the route. Damages caused by improper transportation, storage or installation are not covered by the warranty.

## 1.8 Operational area

### - Appropriate use:

QuietAir 150 fans are used to convey normal or slightly dusty (particles size < 10 µm), little aggressive and humid air, into moderate climate and suitable area of its performance curve (see Airflow sales documentation / Internet). Operation permitted only for fixed installation within buildings. Maximum permitted medium and ambient temperature is 40°C. QuietAir 150 fans conform to protection rating IP45, protection class II and according to VDE0100 part 701 can be installed in zone 1 of your wet room.

### - Rationally foreseeable misuse

The fans are not suitable for use under difficult conditions such as high humidity, aggressive media, longer downtimes, strong pollution, and excessive workload due to climatic, technical or electronic influences. The same applies for the mobile use of this fan (cars, aircrafts, ships, etc.). To perform under these conditions please check with Airflow Developments Limited before installing.

### - Prohibited use

Anything other than the intended use is not permitted. Solids or solid impurities > 10 µm in transporting medium as well as liquids are not allowed. Transporting medium which are aggressive against the fan material as well as abrasive media is not allowed. Usage of the fan in an explosive environment is prohibited.

## 1.9 Performance data

The device type plate is binding for the electrical data; this should conform to the local supply network. On the test stand fan, performance complied with DIN EN ISO 5801.

## 1.10 Noise data

The noise data which relate to distances is valid under free flow conditions. After installation the sound pressure level can vary significantly from the catalog values since it strongly depends on the installation conditions, for instance the absorption capacity of the room, the room size etc.

## CHAPTER 2

### GENERAL NOTES

## 2.0 Qualification of staff

**⚠ Maintenance and installation work must be carried out only by an approved electrician.**

The QT150 HT should not to be used by children and persons with reduced physical, mental or sensory capacities, without proper practical experience or expertise, unless they are controlled or instructed on the product operation by the person(s) responsible for their safety. Children should not play with the device. Cleaning and maintenance must not be carried out by children without supervision.

DANGER

## 2.1 Touch protection

The QT150 HT is supplied with a standard suction side protective grid. Depending on the installation conditions protection against accidental contact on the discharge side may also be required. Appropriate protective grids are available as an accessory.

- According to the installation method (for instance installation in ventilation canals or covered aggregates) fans are already protected and in such cases they do not need a protective grid. It should be noted that the operator is responsible for compliance with the current requirements and is liable for accidents.

## CHAPTER 3

### SPECIFICATIONS/ DIMENSIONS M1/150 F

#### 2.2 Motor protection

The QT150 HT has an energy-saving maintenance-free EC Motor with high efficiency. The motor is equipped with a thermal contact, wired in series, which automatically switches on/off after cooling. If the motor is blocked there will be an attempt to restart it every 3 seconds.

#### 2.3 Start-up performance

To start the motor a certain rotor position is required. If it doesn't detect it, it outputs pulses to the rotor in order to reach this position. This may take a few seconds. After switching off the fan, switch-on inhibit activates the fan for 15 sec. to protect the motor from rapid on/off switching.

#### 3.0 Specifications

Impeller – Ø	137	Electrical supply	NYM-0 4x1,5 mm <sup>2</sup>
Alternating current	1~	Degree of protection	IP 45 (jet-proof)
Voltage/frequency	230 V, 50Hz	Protection class	II
Power input (W)	9 / 6	Weight approx. kg	1.2
Rated current (mA)	80 / 60	Rotational speed	1900/1600
Flow volume (m <sup>3</sup> /h)	260 / 220	Shut down (min.)	6,12,18,24 (adjustable)

#### 3.1 Product lifetime

This unit is designed for a product life of at least 40.000 hours in Speed 1 mode with maximum power in the maximum permissible ambient temperature.

#### 3.2 Accessories

**9041315 2**  
**Speed Switch**

#### 3.3 Dimensions

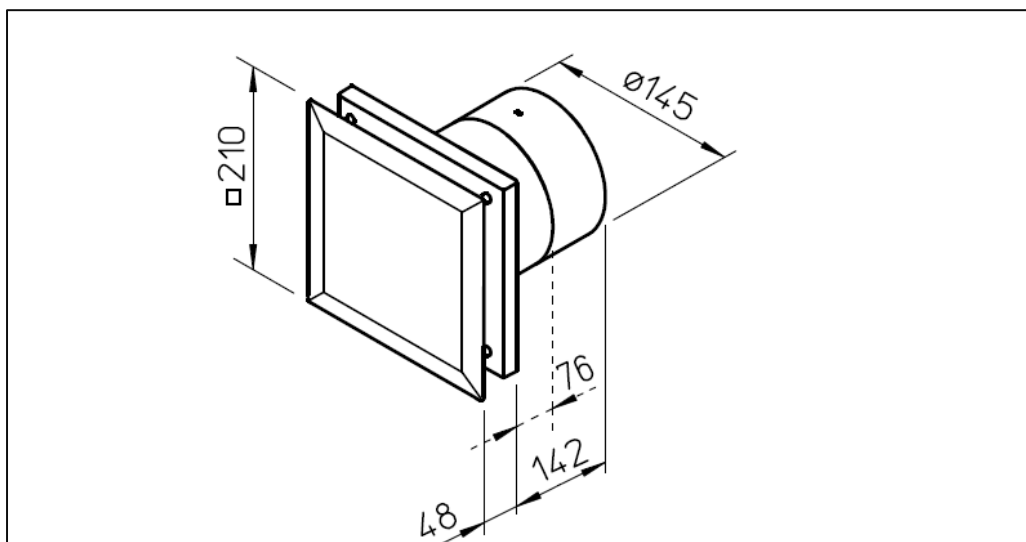

## FUNCTION

All of the following information and instructions are intended for use by authorized electricians. All times may vary slightly due to component tolerances and ambient temperatures.

**Exceed of the humidity threshold or demand ventilation caused by switching the switch will lead to the turning on of the fan. The required ventilation is superior to the humidity control.**

**Automatic mode:** The humidity control works without connecting a switch.

**Demand ventilation:** By connecting e.g. a 2 speed switch from the Airflow range of accessories the fan can be used on different speed levels 1 and 2. The use of the switch is consistent with the functions of the fan by default.

The speed of the fan level is continuously adjustable (factory setting Level 1 - 70%, Level 2 - 100% of the maximum speed). The adjustment applies to both - demand ventilation as well as for the humidity control. In order to ensure a sufficient dehumidification, the rotational speed is in the automatic mode, but always at least 50% in the low stage and at least 80% in the high stage, even with a smaller potentiometer setting.

### 1. Humidity functions

You can choose between single-stage, dual-stage and continuous humidity functions. The choice of the humidity function is technically bound to the allocation of timer functions to certain fan levels.

- **Single-stage humidity function**

In the single-stage humidity function, the desired dehumidification stage can be preset. The fan is turned on at the stage when dehumidification is required. This feature is set at the factory to ensure a speedy dehumidification.

- **Dual-stage humidity function**

During dual-stage humidity function, the fan will turn on first to the stage with a lower speed. Once the humidity level reaches 10%, the fan will turn on to the higher stage and will remain on as long as the humidity remains above the threshold. It will turn back to the lower stage automatically after the humidity level comes back down to less than 10 percent. Switching between the stages should have a minimum runtime of 10 minutes. This function returns soft dehumidification to the humidity values over the switching on threshold. A continued rise in the room's humidity then results in strong dehumidification.

- **Infinitely variable humidity function**

During continuous humidity function the air volume is automatically controlled, depending on the room's humidity. When the humidity increases, the fan speed increases. This ensures continuously increasing dehumidification during slowly rising humidity. It is useful to go back to the factory setting to start the dehumidification even at a low level of humidity in the room (e.g. left stop corresponds dehumidification from 40% RH, this corresponds to about 20% of the fan speed).

### 2. Humidity Control

The electronics detect two different types of humidity increases in the air, it distinguishes between a slow and rapid increase of moisture. The switch-on threshold is adjustable between 40% RH and 90% RH.

- **High humidity (slower increase in humidity)**

For slow increase in humidity (caused possibly by washing, drying of textiles, temperature lowering) the fan can be set above the threshold (factory setting is set to 70% RH) and runs until the humidity has dropped by 10%.

- **Occasional control (faster increase in humidity)**

With a rapid increase in humidity (caused possibly by showering, bathing) the fan turns on as early as possible before reaching the set threshold, to effectively eliminate excessive humidity and restore the comfort zone in the room. When reaching the set point threshold, the fan shuts down according to the timer setting. The switch-off threshold is fixed at 10% below the set point.

**3. Runtime limit**

In cases with lasting moisture accumulation (when the relative humidity of the inflowing air is already above the set point, or permanently damp laundry is in the room, or poor air exchange due to a small-sized room or clogged air vent opening) the fan will shut down automatically after 2 hours. During stop time any humidity measurement will be ignored. The required ventilation continues to be activated enabling ventilation on demand, until the stop time function is terminated.

**There are two possible stopping times:**

**Short stopping time:**

The humidity has dropped down after two hours under the adjusted switch on threshold, but hasn't yet reached switching off threshold. The fan switches off; it runs a short stop time of one hour.

Background: *There is a humidity decrease (reduction) during the fan operation. The reduction however hasn't been enough to fall below the turn off threshold. Short stop time activated since it can be assumed that after a short break the humidity can still be effectively reduced.*

**Long stopping time:**

The humidity hasn't dropped down after two hours under the adjusted switch on threshold. The fan is switches off; it runs a long stop time of six hours.

Background: *Since the humidity value hasn't fallen below the set point value, it can be assumed that another venting makes no sense.*

**4. Hygrostat function**

The control switches are as a "smart" hygrostat. The humidity operation is identical, but without shutting down after the run on time limit, if the switch off threshold is not exceeded.

**5. Switch ON delay**

The fan will turn on after the set delay start time (0, 45, 90, 120 sec.). The delay is only performed at standstill of the fan. When switching between on-going stages applicable, switch ON delay will be ignored. By simultaneous activation of both stages, switch ON delay is also not taken into account.

**6. Push-button operation**

When no switch on delay is activated, switch inputs can be controlled by an impulse button. To do so, on the relevant stage, the timer function has to be activated.

The button must be pressed for more than 0.5 sec. If a stage was activated by button, the corresponding stage will switch off automatically at the end of the stopping time.



## 7. Follow-up

After switching off the current stage, the fan turns off after the set run time. The length of the overrun time is adjusted by the DIP switches 3 and 4 (6, 10, 15, 21 minutes). If you switch between stages, the delay time will be ignored. By simultaneous shut down of the both stages, applicable delay time can be ignored. As always, the technical signal is faster, so the controller response will depend on the last signal.

## CHAPTER 5

### CLEANING / DISMANTLING

DANGER

DANGER

## 5.0 Cleaning

### ⚠ Safety instructions listed in Chapter 1.2 should be observed!

- Before cleaning always ensure that the fan is isolated from the power supply and secured against restarting!
- Clean cover, protective guard and visible housing parts (the external housing of the fan) with a damp cloth!
- Do not use any aggressive or paint solvent cleaning agents!
- High pressure cleaners or water sprays should not be used!

## 5.1 Cover dismantling

1. Isolate the fan from the power supply and secure against restarting.
2. Pull the side pieces (cover plates) of the upper part of the housing outwards (see Fig 1/Fig 2) to un-latch it and upwards until the cover plate is opened.

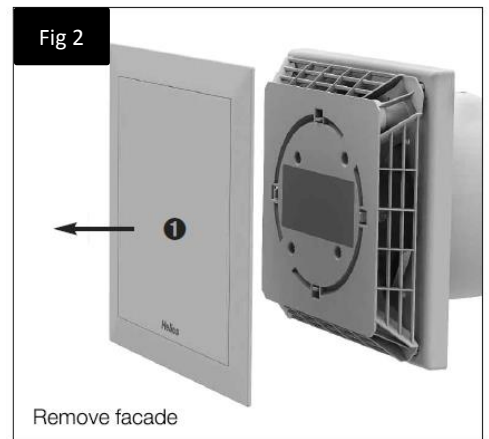

All of the following information and instructions are intended for use by authorized electricians.

**CHAPTER 6**  
**INSTALLATION**

**6.0 Scope of delivery / Mechanical Installation**

A visual inspection upon delivery should be performed including a check to ensure all components are present. Take the unit out of the box immediately before installation in order to avoid possible damage and contamination during the transport as well as at the construction site.

Scope of delivery:

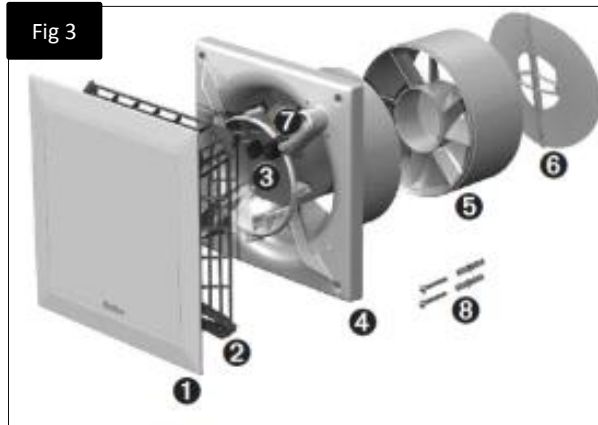

1. **Cover**
2. **Terminal compartment cover** incl. 4x fastening screws
3. **Control board**
4. **Plastic housing** with impeller
5. **Guide vane**, with limited mounting depth removable
6. **Backdraft shutter**, removable
7. **Cable support sleeve** x 2
8. **Mounting kit**  
2x screws with plugs for a wall mounting
9. **Foam strips**

**DANGER**

**6.1 Preparation for wall mounting**

**⚠ Safety instructions listed in Chapter 1.2 must be observed!**

The fan is supplied as a complete unit, which is delivered ready for connection. The installation and set-up of the fan should be performed only after final cleaning to avoid damage and contamination of the ventilation unit.

After unpacking and before installation the following points must be checked:

- if any transport damage is noticed,
- broken or bent parts
- free rotation of the impeller

**6.2 Installation**

The QT150 HT is designed for direct wall mounting. The housing should not be deformed or warped during the installation. Choose a flat location for mounting. Fans can be heavy and are sometimes unwieldy. Proper precautions should be taken, to ensure the assembly is well supported and stable before lifting into position. Fans should be mounted on a strong and stable surface using appropriate fasteners.

**1. Cable outlet in the wall**

- Position of the cable outlet in the dark area is variable (Fig 4).
- Clearance to the pipe centre depending on the cable outlet  $r = 83 \text{ mm}$  (at a variable position from  $0$  up to  $360^\circ$ ).
- For an easy assembly, it is recommended to place outlet as shown in fig 5 ( $90^\circ$  rotatable). The optimal position is at  $45^\circ$  when the cable outlet placed directly at the position of the cable support sleeve.
- QT150HT Pipe inner diameter =  $\varnothing 150 \text{ mm}$
- Clearance to room corners: at least  $130 \text{ mm}$  from the pipe centre
- During the wiring the side recess for the cable entry in the housing (Fig 7, Position1) should be broken out.

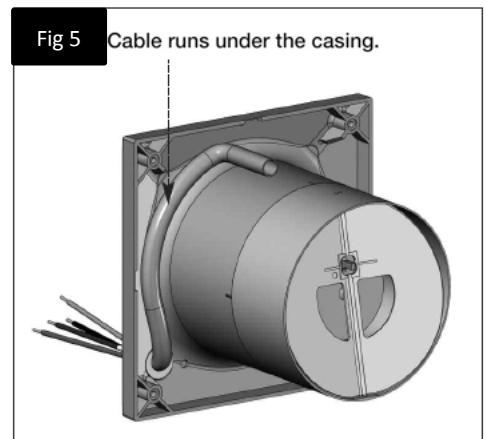
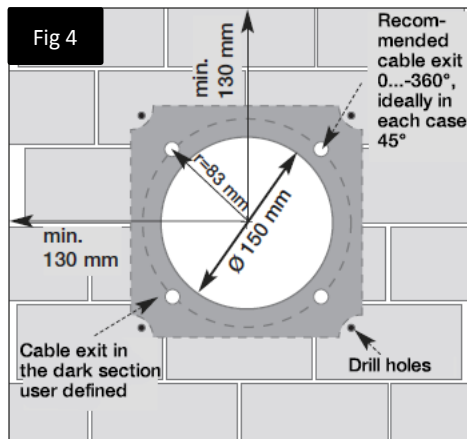

## 2. Boreholes

Position the housing, then mark and drill the holes and mount it with at least two fastening screws and wall plugs.

## 3. Backdraft shutter and guide vane

- If required backdraft shutter (included in delivery) can be installed behind the guide vane (Fig 6).
- During the housing installation, the guide vane should be mounted vertically. Grating can be rotated by 90°.
- Before final assembly stick on the rubber foam strips (included in delivery) (Fig 6).

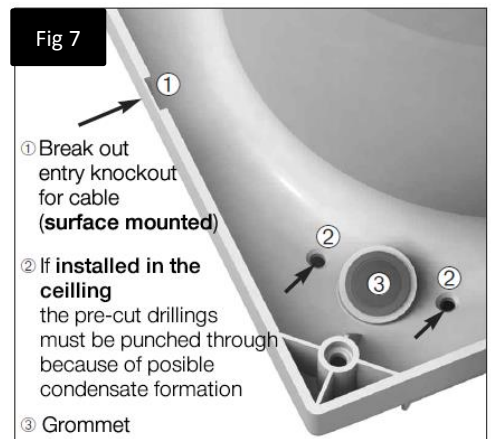
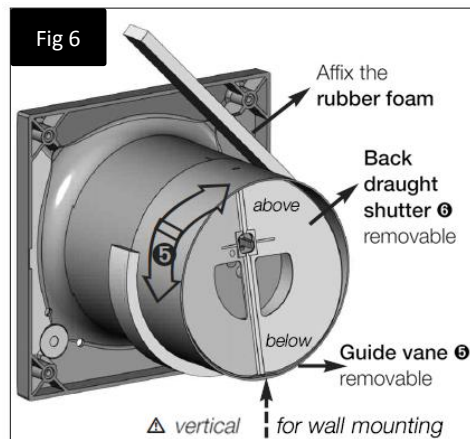

### 6.3 Electrical installation/Commissioning

⚠ Safety instructions listed in Chapter 1.2 should be observed

- All electrical installations to be carried out by an approved electrician in accordance with presented manual and wiring diagrams.
- The relevant standards, safety regulations (for instance DIN VDE 0100) and technical connection regulations of the energy supply company should be observed!
- An all-pole mains switch/isolation switch, with at least a 3 mm contact opening (VDE 0700 T1 7.12.2 / EN 60335-1) is mandatory by law!
- Network configuration, voltage and frequency of the power source should match the information on the rating plate.

### 6.4 Cable connection

- Use NYM cable with a customary maximum diameter of 11 mm.
- Prepunch grommet with a round tool or pierce directly with the supply line (Fig. 7)
- Remove cable sheath to a length of 135 mm. Strip back each wire's insulation by about 8 mm.
- Carefully slide cable through the grommet.
- The wiring diagram (SS-1082 which can be found on Page 16) should always be used to ensure proper wire placement.
- Check sealing of the connection cables and cable wires clamp.
- If mounted at the inlet spout the sheathed cable does not enclose evenly, the spout should be additionally sealed with silicone. Otherwise, the IP protection will be compromised.
- The connection cable should be positioned in such a way that in case of water entering, water may not penetrate along the cable. Cables should be laid in such a way that they do not run over sharp edges.
- Check the fan according to the intended use.
- Supply voltage should match the name plate data.
- Ensure secure mounting and proper electrical installation of the device.
- Check the rotation of the impeller.
- All parts of the fan, especially screws and protective grid must be checked for tightness. Do not mislay the screws included with the unit!
- **Ensure that the necessary protective guard is installed, as the unit cannot be operated without it.**
- During the trial run the fan should be checked for vibrations and noise.
- Power consumption should match the name plate data.

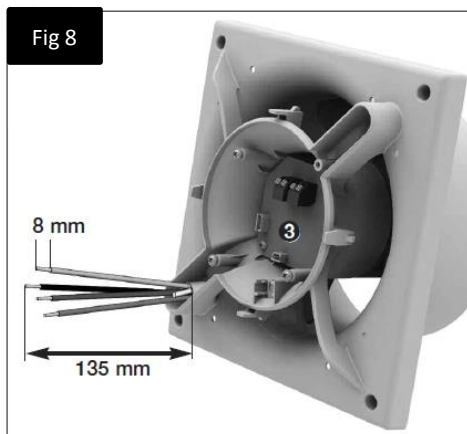

- Length of individual wires 135 mm
- Wire stripping 8 mm
- Strip the non-metallic sheathed cable which sits flush with cable duct

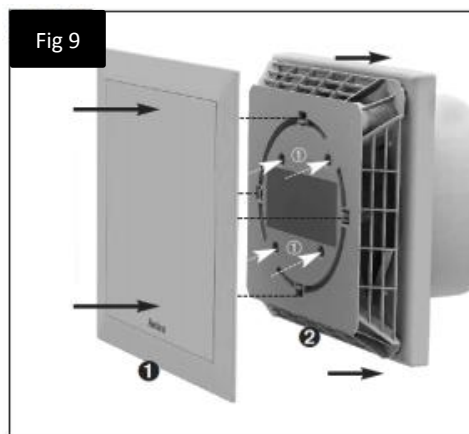

1. Terminal compartment cover put on the plastic housing and screw tight
2. Fit and snap in the cover

## 6.5 Mounting

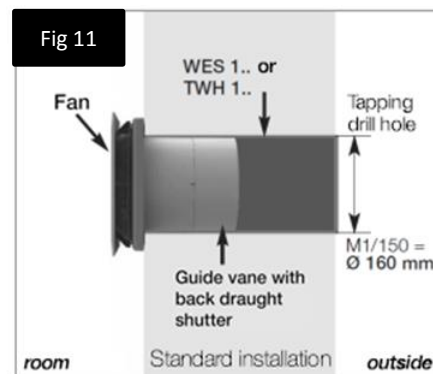
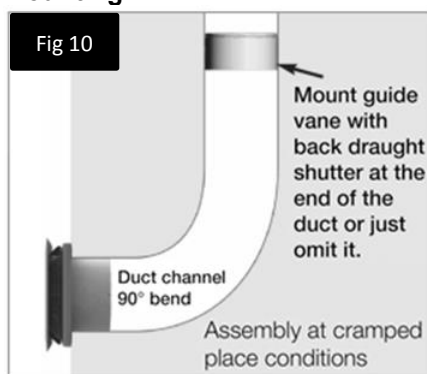

**DANGER**

## 6.6 Operation

**⚠ Safety instructions listed in Chapter 1.2 must be observed!**

To guarantee the proper function of the fan, the following should be checked regularly:

- Appearance of dust or dirt in the housing (on the motor and impeller)
- Free rotation of the impeller
- Appearance of excessive vibration and noise

**In case of problems with one of the points listed above maintenance should be carried out according to the instructions in Chapter 8.**

7.0 Function description QT150 HT (Humidity Timer Model)

Exceeding the humidity threshold or ventilation on demand by switching the switch leads to activation of the fan.

**In case of defective humidity sensor both the automatic mode and the demand ventilation won't work. This ensures that failure is detected.**

1. Terminal assignment

- Terminal N / L

Terminal N and L have to be connected to the 230V operating voltage. Thus the humidity control is already fully functional.

- Terminal 1

Terminal 1 activates stage 1.

- Terminal 2

Terminal 2 activates stage 2.

- Both terminals

The last specification conducts

DANGER

Speed for the stage 1 and stage 2 can be adjusted via the corresponding potentiometer (P1 for stage 1, P2 for stage 2) continuously between 20% and 100% of maximum speed (original manufacturer's settings stage 1 – approx.70% and stage 2 – approx.100%). The adjustment applies to both the demand ventilation as well as for the humidity control. To ensure sufficient dehumidification, speed is in automatic mode but always at least 50% for stage 1 and at least 80% for stage 2 even at small potentiometer.

**Any changes of the DIP switch or potentiometer settings must be carried out only by authorized and qualified electricians. The device must be disconnected (all-pole) from power supply. A change of the DIP switch is allowed only after switching off mains supply.**

**All timer settings may vary slightly due to component tolerances and ambient air temperatures.**

2. Potentiometer settings

If a higher value is desired starting from the factory default, the potentiometer must be turned clockwise or higher. Conversely, the potentiometer is rotated counter clockwise for a lower value. The figure below indicates the factory setting of the potentiometer.

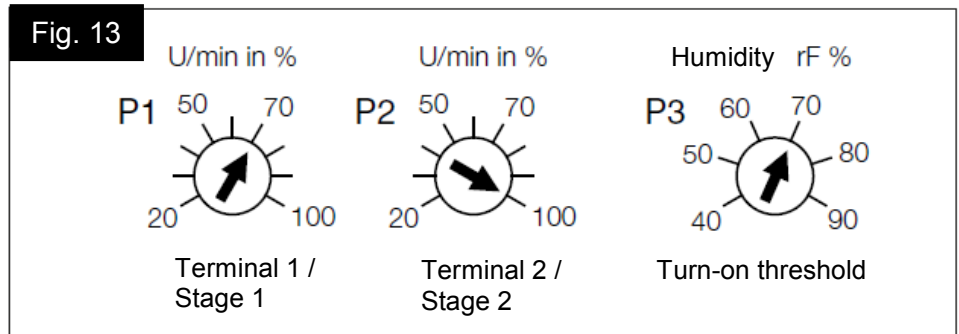

### 3. Humidity functions

Single-stage, dual-stage and infinitely variable humidity function can be chosen with a combination of dip switches 6, 7 and 8. The choice of the humidity function is technically at certain fan levels bound to the allocation of timer functions (see table below).

- **Single-stage humidity function**

In the single-stage humidity function, the desired dehumidification stage can be preset. The fan is turned on at the stage when dehumidification is required. This feature is set at the factory to ensure a speedy dehumidification.

- **Dual-stage humidity function**

During dual-stage humidity function the fan will turn on first to the stage with a lower speed. Once the humidity level reaches 10%, the fan will turn on to the higher stage and will remain on as long as the humidity remains above the threshold. It will turn back to the lower stage automatically after the humidity level comes back down to less than 10 percent. Switching between the stages should have a minimum runtime of 10 minutes. This function returns soft dehumidification to the humidity values over the switching on threshold. A continued rise in the room's humidity then results in strong dehumidification.

- **Infinitely variable humidity function**

During continuous humidity function, the air volume is automatically controlled, depending on the room humidity. When the humidity increases, the fan speed increases. This ensures continuously increasing dehumidification during slowly rising humidity. It is useful to go back to the factory set switch on to start the dehumidification even at a low level of humidity in the room (e.g. left stop corresponds dehumidification from 40% RH, this corresponds to about 20% of the fan speed).

DIP switch			Time function	Dehumidification
6	7	8		
off	off	off	no time	single stage, stage 1
off	on	off	time at stage 2	single stage, stage 2
off	off	on	time at stage 1	single stage, stage 1
off	on	on	time at both stages	two-stage, both stages
on	off	off	no time	infinitely variable
on	on	off	time at stage 2	infinitely variable
on	off	on	time at stage 1	infinitely variable
on	on	on	time at both stages	infinitely variable

### 4. Humidity Control

The electronics detect two different types of humidity rise in the room air, it distinguishes between a slow and rapid increase of moisture.

- **High humidity (slower increase in humidity)**

For slow increase in humidity (e.g. caused by washing, drying of textiles, temperature lowering) the fan can be set above the threshold (factory setting is set to 70% RH) and runs as until the humidity has dropped by 10%. The turn-on threshold can be set by potentiometer P3 between 40% RH and 90% RH. Setting of high accuracy is provided here (see potentiometer setting).

- **Occasional control (faster increase in humidity)**

With a rapid increase in humidity (causes e.g. by showering, bathing) the fan turns on as early as possible before reaching the set threshold, to eliminate effectively excessive humidity and restore the comfort zone in the room.

When reaching the turn off threshold, the fan shuts down according to the timer setting. The switch-off threshold is fixed at 10% below the threshold.

**5. Runtime limit**

In cases with lasting moisture accumulation (when the relative humidity of the inflowing air is already above the set point, or permanently damp laundry is in the room, or poor air exchange due to a small-sized room or clogged air vent opening) the fan will shut down automatically after 2 hours. During stop time any humidity measurement will be ignored. The required ventilation continues to be activated, enabling ventilation on demand, until the stop time function is terminated.

**There are two possible stopping times:**

**Short stopping time:**

The humidity has dropped down after two hours under the adjusted switch on threshold, but hasn't yet reached switching off threshold. The fan is switched off; it runs a short stop time of one hour.

*Background: There is humidity decrease (reduction) during the fan operation. The reduction however hasn't been enough to fall below the turn off threshold. Short stop time activated since it can be assumed that after a short break the humidity can still be effectively reduced.*

**Long stopping time:**

The humidity hasn't dropped down after two hours under the adjusted switch on threshold. The fan is switched off; it runs a long stop time of six hours.

*Background: Since the humidity value hasn't fallen below the set switch on it can be assumed that another venting makes no sense.*

**If no stop times required please enable hygrostat function.**

**6. Hygrostat function**

DIP switch 5 controls the hygrostat function. The control switches are as a "smart" hygrostat. The humidity operation is identical, but without shutdown by the run time limit, if the switch off threshold is not exceeded.

**7. Timer function activation**

Via DIP switches 7 and 8 the time function (delay, overrun timer) can be activated or deactivated at the desired stage.

**8. Switch ON delay**

The switch on delay can be set via DIP switches 1 and 2. Then the fan will turn on after the set delay time (0, 45, 90, 120 sec.). The delay is only performed at standstill of the fan. When switching between on-going stages applicable switch ON delay will be ignored. By simultaneous activation of both stages, switch ON delay is also not taken into account.



### **9. Push-button operation**

When no delay start is activated (DIP switch 1 / 2 = off / off), switch inputs 1 or 2 can be controlled by an impulse button. To do so, on the relevant stage, the timer function has to be activated (DIP switch 7, DIP switch 8).

The button must be pressed for more than 0.5 sec. If a stage was activated by button, the corresponding stage will switch off automatically at the end of the stopping time.

### **10. Follow-up**

After switching off the current stage, the fan turns off after the set run time. The length of the overrun time is adjusted by the DIP switches 3 and 4 (6, 10, 15, 21 minutes). If you switch between stages, the delay timer will be ignored. By simultaneous shut down of the both stages, applicable delay time can be ignored. As always, the technical signal is faster, so the controller response will depend on the last signal.

### **11. Function test – Test mode:**

Upon connection of the operating voltage the fan is for 1 min in a test mode (prerequisite: DIP switches factory settings, see SS-1082).

In this case, switch on delay timer and run on time functions or switching cycle are within the first minute deactivated. The humidity detection remains active in test mode, but comes across during the testing minute only as a "Button" (humidity turn on threshold reached → immediately, turn off threshold fell below → immediately).

## 12. Schematic overview for QT150 HT

Fig. 14

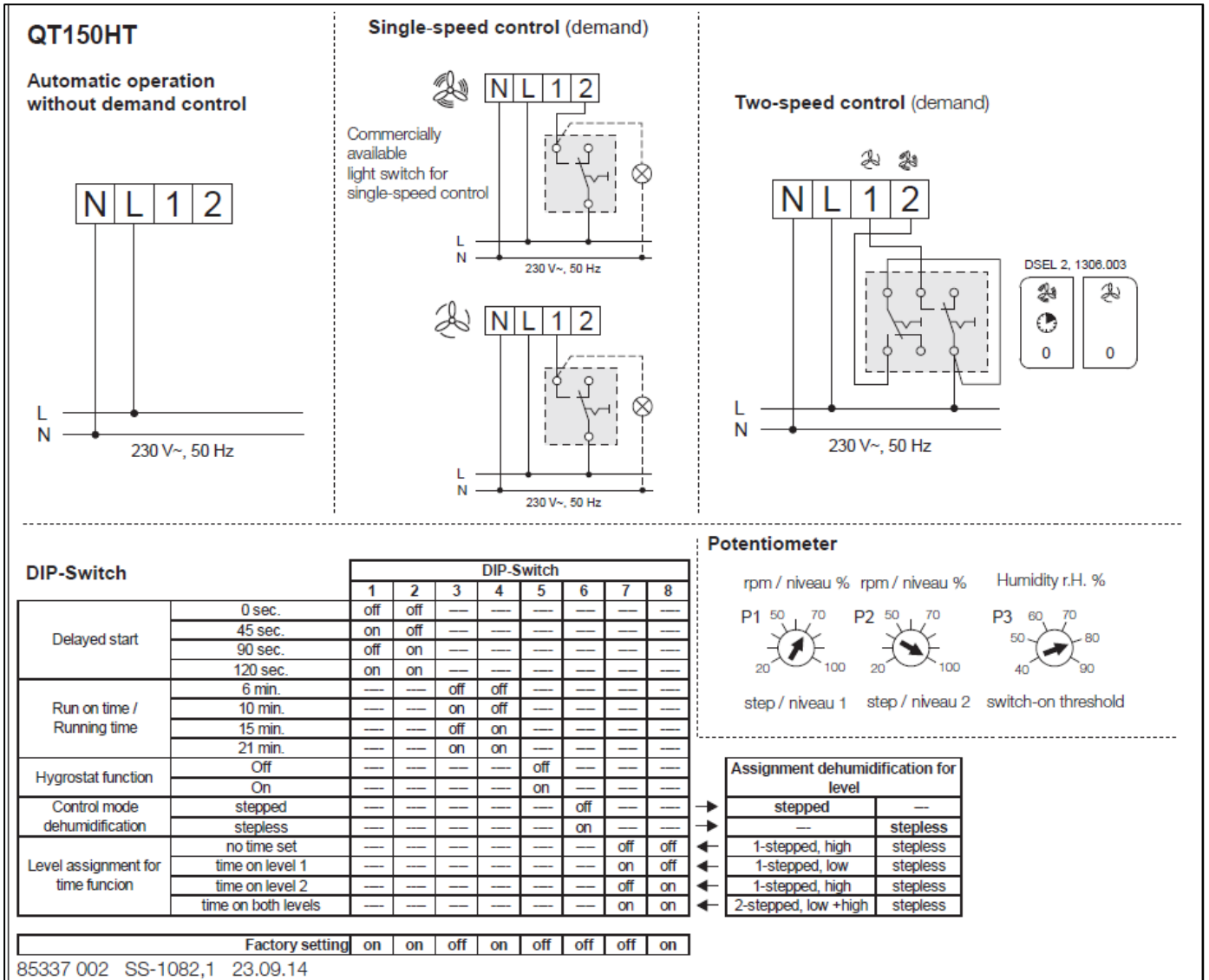

**CHAPTER 8**

**8.0 Care and maintenance**

**CARE AND MAINTENANCE**

**DANGER**

**⚠ Safety instructions listed in Chapter 1.2 must be observed!**

- **Prior to all work always ensure that the fan unit is isolated from the power supply and secured against restarting!**
- In principle the devices are maintenance-free; the unit is not user serviceable. Nevertheless all necessary maintenance work must be carried out by qualified electricians!
- Excessive deposits of dirt, dust, fats etc. on the impeller, motor, protective grids and especially between housing and impeller are not allowed; as it can lead to heavy imbalance in the impeller, overheat the motor or even block the impeller. In those instances the device has to be cleaned.
- In case of no longer use the unit must be serviced before operation.

*Should be examined:*

- Secure mounting of the fan / replace if in doubt
- Remove contaminant deposits
- Mechanical damage, shut down the device, replace damage parts
- Firm seating of bolt connections, loosen screws
- Housing quality (cracks, brittleness of the plastic)
- Overrunning of the impeller, the impeller doesn't run freely, note possible causes of failure in Chapter 8.1
- Bearing noise
- Vibrations – see Chapter 8.1
- Power consumption according to the specifications on the type plate – see Chapter 8.1

**DANGER**

**8.1 Troubleshooting**

**⚠ Safety instructions listed in Chapter 1.2 should be observed!**

**Attention: If the impeller or motor is blocked allow 3 seconds for the restart interval.**

	<b>Causes</b>	<b>Solution</b>
<b>Fan doesn't start</b>	- No voltage	Mains voltage check Check connection according to wiring diagram
	- Blocked impeller	Clear blockage, clean or replace
	- Blocked motor	Contact Airflow Technical Support
<b>Fuse Tripping</b>	- Winding is short-circuiting the motor	Contact Airflow Technical Support
	- Damaged cable or connector	Replace parts, if necessary replace motor (Contact Airflow Technical Support)
	- Connected incorrectly	Check the connection, modify
<b>Vibrations</b>	- Contamination	Clean
	- Mounting vibrancy	Check mounting, repair
<b>Abnormal noises</b>	- Grinding impeller	Clean impeller, replace
	- Bearing damages	Contact Airflow Technical Support
	- Mechanical damages	Perform maintenance
<b>Fan doesn't perform properly</b>	- Insufficient air flow	Check inflow and outflow / keep clear
	- Wrong voltage	Check connection / modify
	- Contamination	Clean
	- Insufficient back-flow	Extend back-flow



CAUTION

## 8.2 Decommissioning and disposal

**Safety instructions listed in Chapter 1.2 should be observed!**

**During transportation safety instructions listed in Chapter 1.4 should be observed.**

Parts and components of the fan which have reached the end of their lifespan, for instance because of the wear and tear, corrosion, mechanical loading, fatigue and/or other effects that could not be directly discerned, should be disposed in accordance with local and international laws and regulations. The same applies to auxiliary materials such as oils, greases or other substances. The conscious or unconscious re-use of used components such as impellers, bearings, belts, etc. may endanger persons, the environment as well as the equipment itself. Relevant local operating regulations should be observed and applied.

Warranty:

Applicable to units installed and used in the United Kingdom. Airflow's Warranty covers the QuietAir fan for TWO years. The Warranty can be upgraded to THREE years from date of purchase against faulty material or workmanship by registering on our web site at [www.airflow.com](http://www.airflow.com). The Warranty covers the product only and not the installation cost.

In the event of any defective parts being found, Airflow Developments Ltd reserve the right to repair or at our discretion replace without charge provided that the unit

1. Has been installed and used in accordance with the fitting and wiring instructions supplied with each unit
2. Has not been connected to an unsuitable electrical supply
3. Has not been subjected to issue, neglect or damage.
4. Has not been modified or repaired by any person not authorised by Airflow Developments Ltd.
5. Has been installed in accordance with latest Building Regulations and IEE wiring regulations.

Airflow Developments shall not be liable for any loss, injury or other consequential damage, in the event of a failure of the equipment or arising from, or in connection with, the equipment excepting only that nothing in this condition shall be construed as to exclude or restrict liability for negligence.

This warranty does not in any way affect any statutory or other consumer rights.



Airflow Developments Limited  
Aidelle House, Lancaster Road, Cressex Business Park  
High Wycombe, Buckinghamshire  
HP12 3QP, United Kingdom

E-mail: [info@airflow.com](mailto:info@airflow.com)

Telephone: +44 (0) 1494 525252

Facsimile: +44 (0) 1494 461073

[airflow.com](http://airflow.com)

## **Addendum – 10/2016**

The Building Regulations 2010, Statutory Instrument Part 9, paragraph 42, imposes a requirement that testing and reporting of mechanical ventilation performance is conducted in accordance with an approved procedure.

Compliance with this requirement by an assessed and registered 'Competent Person' should follow a 'Best Practice' process and adopt air flow measurement, Method A – The Unconditional Method – using a suitable UKAS certified measuring instrument. Generically referred to as a 'Zero Pressure Air Flow Meter' or 'Powered Flow Meter'.

Further information on this method is detailed in NHBC Building Regulations Guidance Note G272a 10/13 and BSRIA 'A Guide to Measuring air flow rates' document BG46/2015